

UNICOM EVO	DESCRIZIONE CABLAGGIO	CABLE DESCRIPTION
------------	-----------------------	-------------------

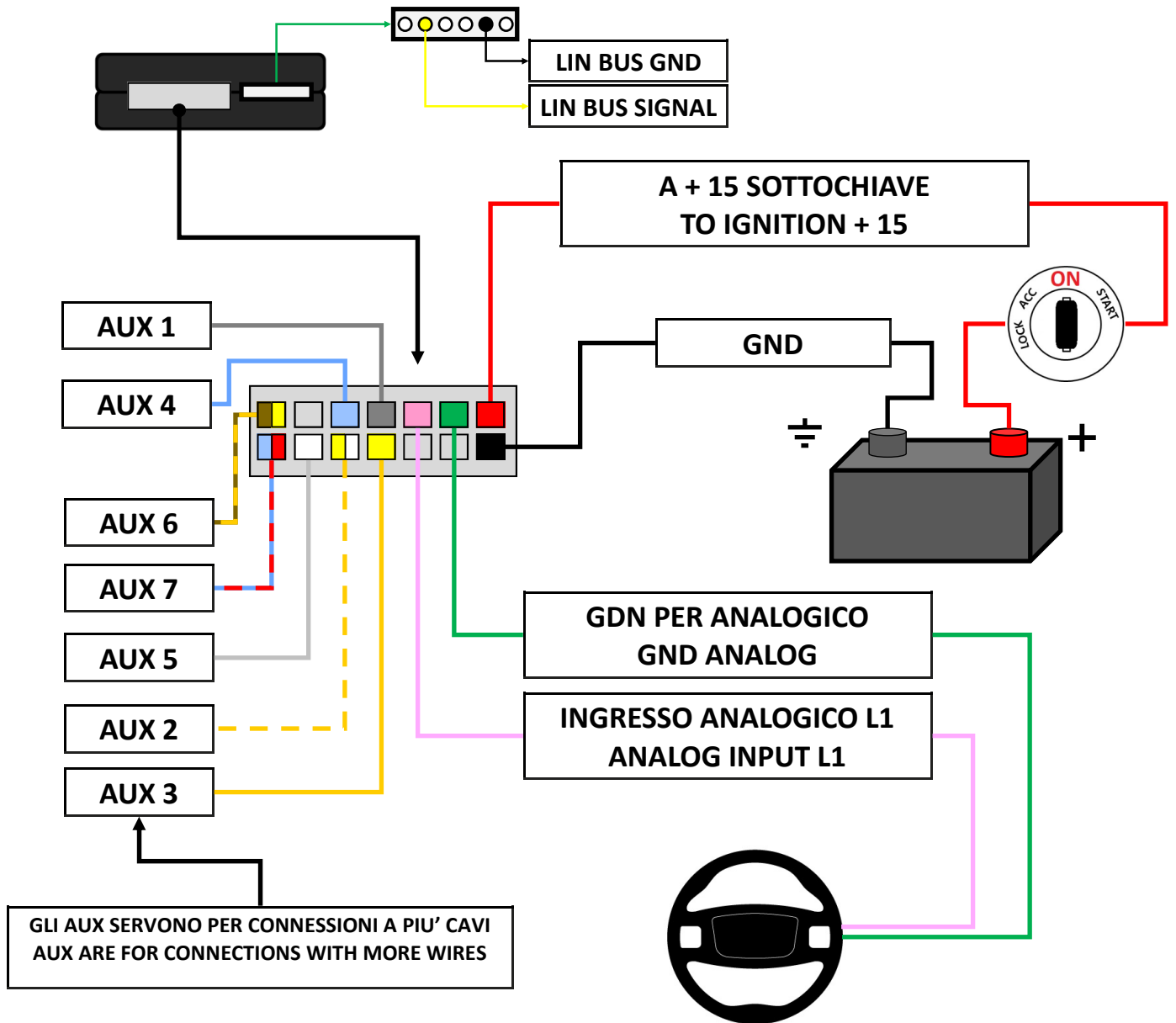

**CONNESSIONE A RADIO CON APPRENDIMENTO RESISTIVO - CONNECTIONS TO RADIO WITH RESISTIVE DIRECT MEMORIZING**

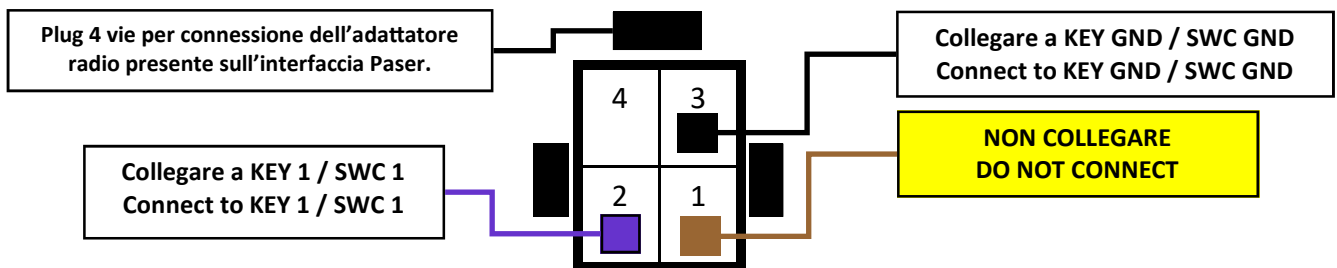

UNICOM EVO ANALOGUE		CONNESSIONI (VISTA CONNETTORI USCITA FILI) NON COLLEGARE I CAVI PRESENTI SUL CABLAGGIO NON CITATI NEGLI SCHEMI		CONNECTIONS (WIRES EXIT VIEW) DO NOT CONNECT WIRES PRESENT ON THE HARNESS BUT NOT MENTIONED IN THE DIAGRAMS	
<p><b>Panda</b> <b>Marea</b> <b>Barchetta</b></p>		<p><b>147 156 GT</b> <b>GTV</b> <b>DUCATO</b> <b>MULTIPLA</b></p>		<p><b>16</b></p>	
<p>L1 ROSA L1 PINK GIALLO YELLOW GND VERDE GREEN</p>		<p>L1 ROSA L1 PINK GIALLO YELLOW GND VERDE GREEN</p>		<p>L1 ROSA L1 PINK GND VERDE GREEN</p>	
I CONNETTORI SONO NEL VANO RADIO		CONNECTORS ARE LOCATED IN THE RADIO SLOT			
<p><b>&gt;2002</b></p>		<p><b>&gt;2002</b></p>		<p><b>&gt;2002</b></p>	
<p>L1 ROSA L1 PINK GRIGIO GREY GND VERDE GREEN</p>		<p>L1 ROSA L1 PINK GRIGIO GREY GND VERDE GREEN</p>		<p>L1 ROSA L1 PINK GRIGIO GREY GND VERDE GREEN</p>	
I CONNETTORI SONO NEL VANO STERZO		CONNECTORS ARE LOCATED BELOW THE STEERING WHEEL			
<p><b>ISO</b></p>		<p><b>OEM</b></p>			
<p>L1 ROSA L1 PINK GND VERDE GREEN</p>		<p>L1 ROSA L1 PINK GND VERDE GREEN</p>			
I CONNETTORI SONO NEL VANO RADIO		CONNECTORS ARE LOCATED IN THE RADIO SLOT			
<p><b>OLD</b></p>		<p><b>OEM</b></p>		<p><b>FAKRA</b></p>	
<p>L1 ROSA L1 PINK GND VERDE GREEN</p>		<p>L1 ROSA L1 PINK GND VERDE GREEN</p>		<p>L1 ROSA L1 PINK POS 6 GND VERDE GREEN POS 8</p>	
I CONNETTORI SONO NEL VANO RADIO		CONNECTORS ARE LOCATED IN THE RADIO SLOT			
<p><b>ISO</b></p>		<p><b>OEM &gt;2018</b></p>		<p><b>OEM 2019</b></p>	
<p>L1 ROSA L1 PINK GND VERDE</p>		<p>L1 ROSA L1 PINK GND VERDE</p>		<p>L1 ROSA L1 PINK GND VERDE</p>	
I CONNETTORI SONO NEL VANO RADIO		CONNECTORS ARE LOCATED IN THE RADIO SLOT			
<p><b>PAJERO</b></p>		<p><b>OUTLANDER</b> <b>ASX</b> <b>LANCER</b></p>		<p><b>L200</b></p>	
<p>L1 ROSA L1 PINK GND VERDE</p>		<p>L1 ROSA L1 PINK GND VERDE</p>		<p>L1 ROSA L1 PINK GND VERDE</p>	
I CONNETTORI SONO NEL VANO RADIO		CONNECTORS ARE LOCATED IN THE RADIO SLOT			
<p><b>S2000 (09)</b></p>		<p><b>ACCORD (08)</b> <b>INSIGHT (07)</b></p>		<p><b>FRV</b></p>	
<p>L1 ROSA L1 PINK GND VERDE</p>		<p>L1 ROSA L1 PINK GND VERDE</p>		<p>L1 ROSA L1 PINK GND VERDE</p>	
I CONNETTORI SONO NEL VANO RADIO		CONNECTORS ARE LOCATED IN THE RADIO SLOT			
<p><b>CIVIC</b> <b>CRV</b> <b>JAZZ</b> <b>2007</b></p>		<p><b>ISO</b></p>		<p><b>NISSAN</b></p>	
<p>L1 ROSA L1 PINK GND VERDE</p>		<p>L1 ROSA L1 PINK GRIGIO GREY GND VERDE GREEN</p>		<p>L1 ROSA L1 PINK GRIGIO GRY GND VERDE GREEN</p>	
I CONNETTORI SONO NEL VANO RADIO		CONNECTORS ARE LOCATED IN THE RADIO SLOT			
<p><b>NISSAN</b></p>		<p><b>NISSAN</b></p>		<p><b>NISSAN</b></p>	
<p>L1 ROSA L1 PINK GRIGIO GREY GND VERDE GREEN</p>		<p>L1 ROSA L1 PINK GND VERDE GREEN GRIGIO GRY</p>		<p>L1 ROSA L1 PINK GRIGIO GREY GND VERDE GREEN</p>	
I CONNETTORI SONO NEL VANO RADIO		CONNECTORS ARE LOCATED IN THE RADIO SLOT			

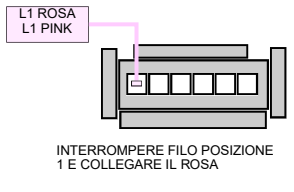
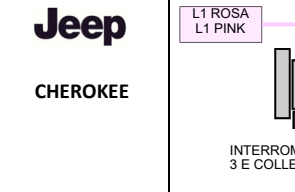
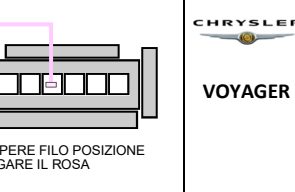
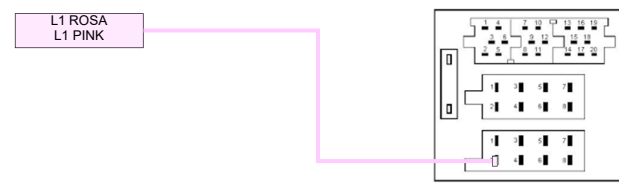
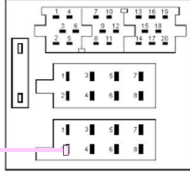
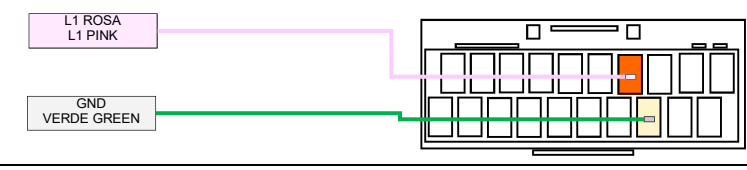
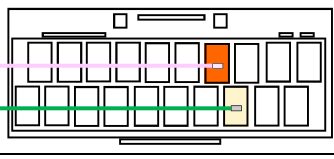
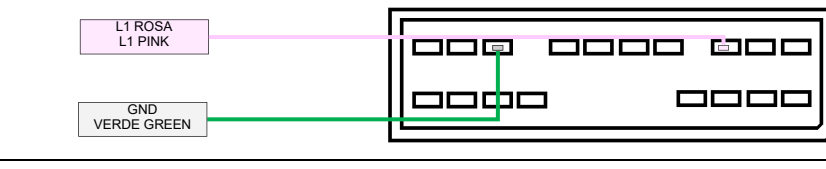
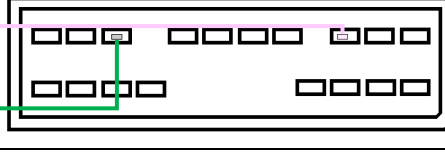
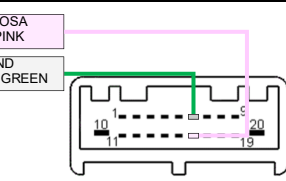
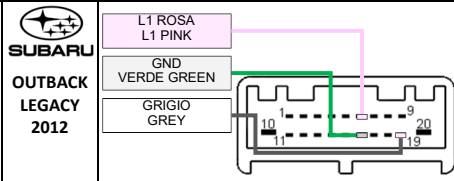
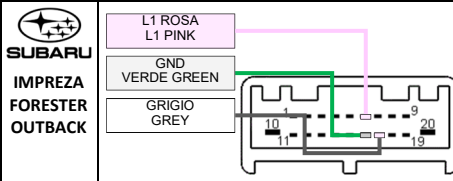
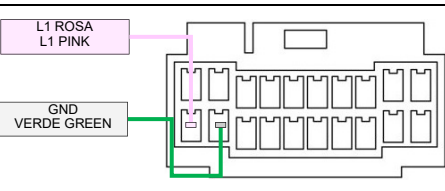
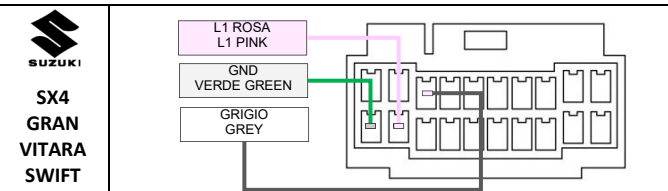
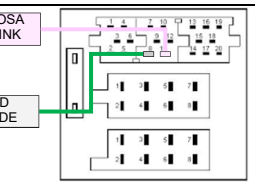
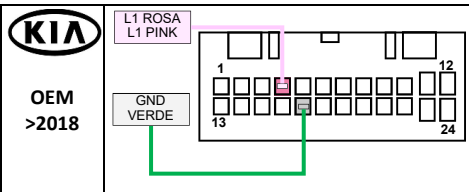
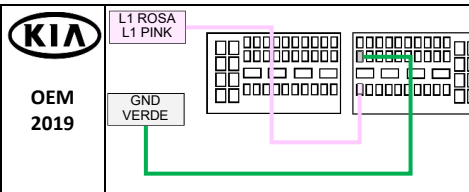
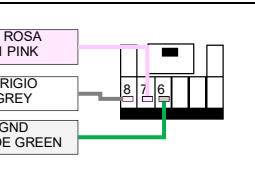
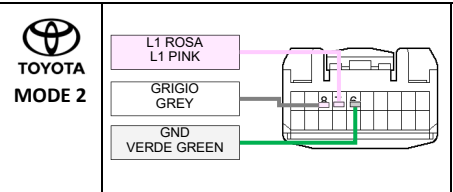
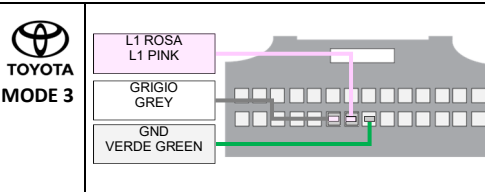
UNICOM EVO ANALOGUE		CONNESSIONI (VISTA CONNETTORI USCITA FILI) NON COLLEGARE I CAVI PRESENTI SUL CABLAGGIO NON CITATI NEGLI SCHEMI		CONNECTIONS (WIRES EXIT VIEW) DO NOT CONNECT WIRES PRESENT ON THE HARNESS BUT NOT MENTIONED IN THE DIAGRAMS	
<p><b>Jeep</b></p> <p><b>GRAND CHEROKEE</b></p>  <p>INTERROMPERE FILO POSIZIONE 1 E COLLEGARE IL ROSA</p>		<p><b>Jeep</b></p> <p><b>CHEROKEE</b></p>  <p>INTERROMPERE FILO POSIZIONE 3 E COLLEGARE IL ROSA</p>		<p><b>CHRYSLER</b></p> <p><b>VOYAGER</b></p>  <p>INTERROMPERE FILO POSIZIONE 2 E COLLEGARE IL ROSA</p>	
<p>I CONNETTORI SONO NEL SOTTO LO STERZO      CONNECTORS ARE LOCATED DOWN THE STEERING WHEEL</p>					
<p><b>ISO</b></p> 					
<p>I CONNETTORI SONO NEL VANO RADIO      CONNECTORS ARE LOCATED IN THE RADIO SLOT</p>					
<p><b>LAND-ROVER</b></p> <p><b>RANGE ROVER FREELANDER 2</b></p> 					
<p>I CONNETTORI SONO NEL VANO RADIO      CONNECTORS ARE LOCATED IN THE RADIO SLOT</p>					
<p><b>SSANGYONG</b></p> <p><b>KYRON ACTYON KODANDO</b></p> 					
<p>I CONNETTORI SONO NEL VANO RADIO      CONNECTORS ARE LOCATED IN THE RADIO SLOT</p>					
<p><b>SUBARU</b></p> <p><b>IMPREZA FORESTER OUTBACK</b></p> 		<p><b>SUBARU</b></p> <p><b>OUTBACK LEGACY 2012</b></p> 		<p><b>SUBARU</b></p> <p><b>IMPREZA FORESTER OUTBACK</b></p> 	
<p>I CONNETTORI SONO NEL VANO RADIO      CONNECTORS ARE LOCATED IN THE RADIO SLOT</p>					
<p><b>SUZUKI</b></p> <p><b>SX4 GRAN VITARA SWIFT</b></p> 		<p><b>SUZUKI</b></p> <p><b>SX4 GRAN VITARA SWIFT</b></p> 			
<p>I CONNETTORI SONO NEL VANO RADIO      CONNECTORS ARE LOCATED IN THE RADIO SLOT</p>					
<p><b>KIA</b></p> <p><b>ISO</b></p> 		<p><b>KIA</b></p> <p><b>OEM &gt;2018</b></p> 		<p><b>KIA</b></p> <p><b>OEM 2019</b></p> 	
<p>I CONNETTORI SONO NEL VANO RADIO      CONNECTORS ARE LOCATED IN THE RADIO SLOT</p>					
<p><b>TOYOTA</b></p> <p><b>MODE 1</b></p> 		<p><b>TOYOTA</b></p> <p><b>MODE 2</b></p> 		<p><b>TOYOTA</b></p> <p><b>MODE 3</b></p> 	
<p>I CONNETTORI SONO NEL VANO RADIO      CONNECTORS ARE LOCATED IN THE RADIO SLOT</p>					

<p><b>UNICOM EVO ANALOGUE</b></p>	<p><b>CONNESSIONI</b>  <b>(VISTA CONNETTORI USCITA FILI) NON COLLEGARE I CAVI PRESENTI SUL CABLAGGIO NON CITATI NEGLI SCHEMI</b></p>	<p><b>CONNECTIONS (WIRES EXIT VIEW) DO NOT CONNECT WIRES PRESENT ON THE HARNESS BUT NOT MENTIONED IN THE DIAGRAMS</b></p>
-----------------------------------	--	---

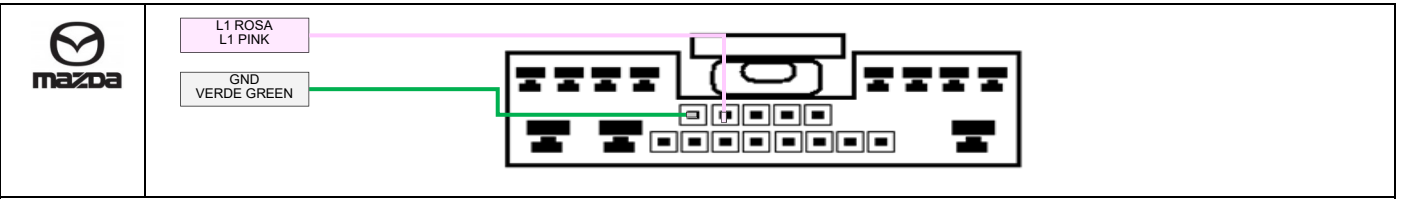

I CONNETTORI SONO NEL VANO RADIO

CONNECTORS ARE LOCATED IN THE RADIO SLOT

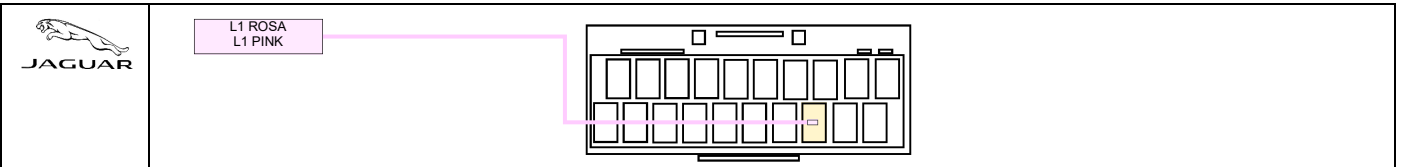

I CONNETTORI SONO NEL VANO RADIO

CONNECTORS ARE LOCATED IN THE RADIO SLOT

Le informazioni riportate in questo manuale e nei suoi allegati sono puramente a scopo informativo pertanto possono subire modifiche senza preavviso. Al momento della pubblicazione le informazioni risultano corrette ed attendibili. Tuttavia Paser non può essere ritenuta responsabile per eventuali conseguenze derivanti da errori, omissioni o incongruenze del presente manuale e dei suoi allegati (ad. es. per l'eventuale mancato recupero di configurazioni audio originali dei veicoli). Paser si riserva il diritto di migliorare/modificare il prodotto o il manuale senza l'obbligo di notifica agli utenti.

Information in this guide and its attachments are for information purposes only, therefore, they are subject to change without notice. At the time of publication the information is correct and reliable. However Paser can not be held responsible for any consequences resulting from errors, omissions or incongruence of this manual (for ex. missed audio configuration back-up of the vehicles). Paser reserves the right to improve / change the product or manual without obligation to notify users.